



# Fellowes

THE WORLD'S TOUGHEST SHREDDERS™



## FS-9C

Please read these instructions before use.

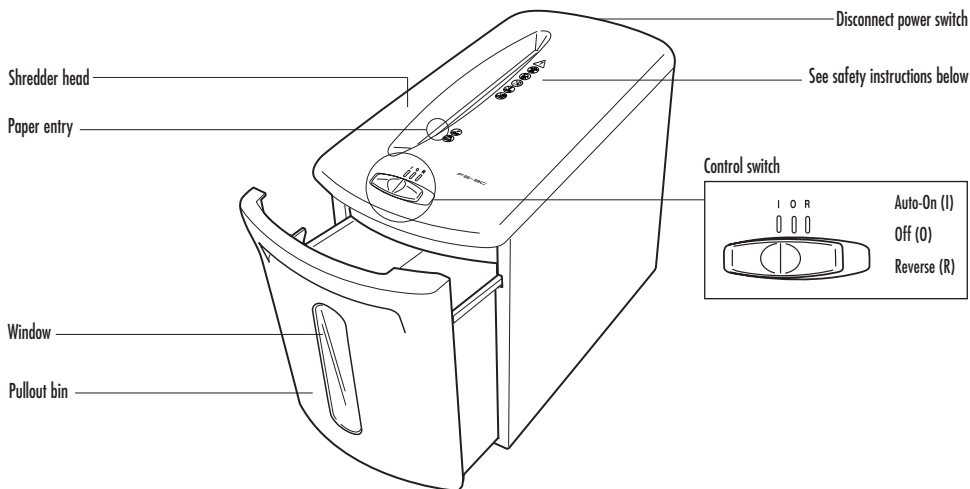

## CAPABILITIES

**Will shred:** Paper, credit cards and staples

**Will not shred:** Continuous forms, adhesive labels, transparencies, newspaper, cardboard, paper clips, laminates or plastic other than noted above

**Paper shred size:**

Cross-Cut ..... 3.9 x 50mm

**Maximum:**

Sheets per pass (Cross-Cut) ..... 6\*  
 Passes per day ..... 25-50  
 Cards per pass ..... 1  
 Cards per day ..... 10  
 Paper width ..... 230mm  
 Continuous operation ..... 10 minutes

\*70g, A4 paper at 220-240v, 1.0Amps, heavier paper, humidity or other than rated voltage may reduce capacity.

## IMPORTANT SAFETY INSTRUCTIONS — Read Before Using!

### WARNING



- Keep away from children and pets. Keep hands away from paper entry. Always unplug when not in use.
- Keep foreign objects – gloves, jewelry, clothing, hair, etc. – away from shredder openings. If object enters top opening, switch to Reverse (R) to back out object.



- Never use aerosol, petroleum based or other flammable products on or near shredder. Do not use canned air on shredder.



- Do not use if damaged or defective. Do not open shredder head. Do not place near or over heat or water source.



- 6 sheets per pass to avoid jams.

### CAUTION

- Avoid touching exposed blades under Cross-Cut shredder head.

- The grounded socket-outlet shall be installed near the equipment and shall be easily accessible.

# OPERATION

Shredder comes ready to use. Disconnect Power Switch must be in ON (I) position to operate shredder. Insert waste bag for easy disposal.



**Continuous operation:**  
10-minute maximum

**NOTE:** Shredder runs briefly after each pass to clear entry. Continuous operation beyond 10-minutes will trigger 20-minute cool down period.



Set to Off (0)  
and plug in



Set to Auto-On (I)

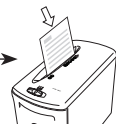

Feed into paper entry  
and release

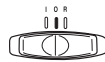

Set to Off (0)  
and unplug

## PAPER



Hold card  
at edge



Press Auto-On (I)

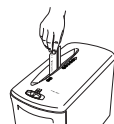

Feed into center of entry  
and release

# TROUBLESHOOTING

**Paper jam:** Set to Off (0) and empty bin. Replace bin and follow any or all of the below procedures.

**Shredder doesn't start:**



Set to  
Reverse (R)



Alternate slowly back and forth



Set to Off (0)  
and unplug



Set to  
Reverse (R)



Gently pull uncut paper  
from paper entry.  
Plug in.

Make sure shredder is plugged in

Make sure bin is pushed in

Wait 20 minutes for motor to cool down

Remove and empty bin

# MAINTENANCE

## Cross-Cut:

Run regularly in reverse for one minute

Lubricate when bin is full, or immediately, if:

- Capacity decreases
- Motor sounds different, or Shredder stops running

Follow oiling procedure below and repeat twice.



Set to Off (0)



\*Apply oil  
across entry



Set to Auto-On (I)



Shred one sheet



Set to Reverse (R)  
2-3 seconds



**\*Only use a non-aerosol vegetable oil in long nozzle container such as Fellowes 35250**



# WARRANTY

**LIMITED WARRANTY** Fellowes, Inc. ("Fellowes") warrants the cutting blades of the machine to be free from defects in material and workmanship for 5 years from the date of purchase by the original consumer. Fellowes warrants all other parts of the machine to be free from defects in material and workmanship for 2 years from the date of purchase by the original consumer. If any part is found to be defective during the warranty period, your sole and exclusive remedy will be repair or replacement, at Fellowes' option and expense, of the defective part.

This warranty does not apply in cases of abuse, mishandling, or unauthorized repair. ANY IMPLIED WARRANTY, INCLUDING THAT OF MERCHANTABILITY OR

FITNESS FOR A PARTICULAR PURPOSE, IS HEREBY LIMITED IN DURATION TO THE APPROPRIATE WARRANTY PERIOD SET FORTH ABOVE. In no event shall Fellowes be liable for any consequential or incidental damages attributable to this product.

This warranty gives you specific legal rights. The duration, terms, and conditions of this warranty are valid worldwide, except where different limitations, restrictions, or conditions may be required by local law.

For more details or to obtain service under this warranty, please contact us or your dealer.

# W.E.E.E.

---

## English

This product is classified as Electrical and Electronic Equipment. Should the time come for you to dispose of this product please ensure that you do so in accordance with the European Waste of Electrical and Electronic Equipment (WEEE) Directive and in compliance with local laws relating to this directive.

For more information on the WEEE Directive please visit [www.fellowesinternational.com/WEEE](http://www.fellowesinternational.com/WEEE)

---

## French

Ce produit est classé dans la catégorie « Équipement électrique et électronique ». Lorsque vous déciderez de vous en débarrasser, assurez-vous d'être en parfaite conformité avec la directive européenne relative à la gestion des déchets d'équipements électriques et électroniques (DEEE), et avec les lois de votre pays liées à cette directive.

Pour obtenir des plus amples informations sur cette directive, rendez-vous sur [www.fellowesinternational.com/WEEE](http://www.fellowesinternational.com/WEEE)

---

## Spanish

Se clasifica este producto como Equipamiento Eléctrico y Electrónico. Si llegase el momento de deshacerse de este producto, asegúrese que lo hace cumpliendo la Directiva Europea sobre Residuos de Equipamiento Eléctrico y Electrónico (Waste of Electrical and Electronic Equipment, WEEE) y las leyes locales relacionadas con esta directiva.

Para más información acerca de la Directiva WEEE, visite [www.fellowesinternational.com/WEEE](http://www.fellowesinternational.com/WEEE)

---

## German

Dieses Produkt ist als Elektro- Elektronikgerät Gerät klassifiziert. Wenn Sie dieses Gerät eines Tages entsorgen müssen, stellen Sie bitte sicher, dass Sie dies gemäß der WEEE (*European Waste of Electrical and Electronic Equipment*) <<Richtlinie, die Regelungen für die Sammlung und Verwertung von Elektro- und Elektronikgeräten vor gibt>> und in Übereinstimmung mit der lokalen Gesetzgebung in Bezug auf diese Richtlinie tun.

Mehr Informationen zur WEEE-Richtlinie finden Sie hier: [www.fellowesinternational.com/WEEE](http://www.fellowesinternational.com/WEEE)

---

## Italian

Questo prodotto è classificato come Dispositivo Elettrico ed Elettronico. Al momento dello smaltimento di questo prodotto, effettuarlo in conformità alla Direttiva Europea sullo Smaltimento dei Dispositivi Elettrici ed Elettronici (WEEE) e alle leggi locali ad essa correlate.

Per ulteriori informazioni sulla Direttiva WEEE, consultare il sito [www.fellowesinternational.com/WEEE](http://www.fellowesinternational.com/WEEE)

---

## Dutch

Dit product is geclassificeerd als een elektrisch en elektronisch apparaat. Indien u besluit zich te ontdoen van dit product, zorg dan a.u.b. dat dit gebeurt in overeenstemming met de Europese richtlijn inzake afval van elektrische en elektronische apparaten (AEEA) en conform de lokale wetgeving met betrekking tot deze richtlijn.

Voor meer informatie over de AEEA-richtlijn kunt u terecht op [www.fellowesinternational.com/WEEE](http://www.fellowesinternational.com/WEEE)

---

## Swedish

Denna produkt är klassificerad som elektrisk och elektronisk utrustning. När det att dags att omhänderta produkten för avfallshantering se då till att detta utförs i enlighet med WEEE-direktivet om hantering av elektrisk och elektronisk utrustning och i enlighet med lokala bestämmelser relaterade till detta direktiv.

För mer information om WEEE-direktivet besök gärna [www.fellowesinternational.com/WEEE](http://www.fellowesinternational.com/WEEE)

---

## Danish

Denne produkt er klassificeret som elektrisk og elektronisk udstyr. Når tiden er inde til at bortskaffe denne produkt, bedes De sørge for at gøre dette i overensstemmelse med det Europæiske direktiv om affald af elektrisk og elektronisk udstyr (WEEE) og i henhold til de lokale love, der relaterer til dette direktiv.

For yderligere oplysninger om WEEE-direktivet bedes De besøge [www.fellowesinternational.com/WEEE](http://www.fellowesinternational.com/WEEE)

---

## Finnish

Tämä tuote luokitellaan sähkö- ja elektroniikkalaitteeksi. Kun tuote poistetaan käytöstä, se on hävitettävä sähkö- ja elektroniikkalaiteromusta annetun EY:n direktiivin (WEEE) ja direktiivin liittyvän kansallisen lainsäädännön mukaisesti.

Lisätietoja WEEE-direktivistä on osoitteessa [www.fellowesinternational.com/WEEE](http://www.fellowesinternational.com/WEEE)

---

---

## Norwegian

Dette produktet klassifiseres som elektrisk og elektronisk utstyr. Hvis du har tenkt å bortselge dette produktet, vennligst se til at du gjør dette i overensstemmelse med det europeiske WEEE-direktivet (Waste of Electrical and Electronic Equipment) og ifølge lokalt lovverk forbundet med dette direktivet.

For mer informasjon om WEEE-direktivet, vennligst besøk [www.fellowesinternational.com/WEEE](http://www.fellowesinternational.com/WEEE)

---

## Polish

Ten produkt został zaklasyfikowany do grupy urządzeń elektrycznych i elektronicznych. W celu pozbycia się zużytego sprzętu będącego w Państwa posiadaniu należy postępować zgodnie z Europejską Dyrektywą w sprawie zużytego sprzętu elektrycznego i elektronicznego (WEEE) oraz z lokalnie obowiązującym prawem.

Więcej informacji znajdziecie Państwo na stronie [www.fellowesinternational.com/WEEE](http://www.fellowesinternational.com/WEEE)

---

## Russian

Данное изделие классифицировано как электрическое и электронное оборудование. Когда придет время утилизировать данное изделие, пожалуйста, обеспечьте соблюдение Директивы Евросоюза об утилизации отходов электрического и электронного оборудования (Waste of Electrical and Electronic Equipment, WEEE) и местных законов, связанных с нею.

Для получения дополнительной информации о директиве WEEE, пожалуйста, посетите веб-сайт [www.fellowesinternational.com/WEEE](http://www.fellowesinternational.com/WEEE)

---

## Greek

Αυτό το προϊόν είναι ταξινομημένο ως Ηλεκτρικός και Ηλεκτρονικός Εξοπλισμός. Σε περίπτωση που θέλετε ν' απορρίψετε αυτό το προϊόν, παρακαλείσθε να βεβαιωθείτε ότι κάnete την απόρριψη σύμφωνα με την Ευρωπαϊκή Οδηγία σχετικά με τα Απόβλητα Ηλεκτρικού και Ηλεκτρονικού Εξοπλισμού (WEEE) και σύμφωνα με τους τοπικούς νόμους που σχετίζονται μ' αυτή την οδηγία.

Για περισσότερες πληροφορίες σχετικά με την Οδηγία WEEE, παρακαλείσθε να επισκεφτείτε την ιστοσελίδα [www.fellowesinternational.com/WEEE](http://www.fellowesinternational.com/WEEE)

---

## Turkish

Bu ürün, Elektriksel ve Elektronik Ekipman olarak sınıflandırılmıştır. Bu ürünü bertaraf etme zamanı geldiğinde, lütfen bunun Avrupa Elektriksel ve Elektronik Ekipmanları Atılması (WEEE) Yönetmeliği ve bu yönetmelke ilgili yerel kanunlar uyarınca yapıldığından emin olun.

WEEE Yönetmeliği hakkında daha fazla bilgi için lütfen [www.fellowesinternational.com/WEEE](http://www.fellowesinternational.com/WEEE) sitesini ziyaret edin

---

## Czech

Tento výrobek je klasifikován jako elektrické a elektronické zařízení. Po skončení jeho životnosti zajistěte jeho likvidaci v souladu se Směrnicí 2002/96/ES o odpadu z elektrických a elektronických zařízeních (OEEZ) a v souladu s místními předpisy, které s touto směrnicí souvisí.

Více informací o směrnici OEEZ najdete na stránkách [www.fellowesinternational.com/WEEE](http://www.fellowesinternational.com/WEEE)

---

## Slovak

Tento produkt je klasifikovaný ako elektrické a elektronické zariadenie. Ak nastane čas zlikvidovať tento produkt, zabezpe te, prosím, aby ste tak urobili v súlade s Európskou smernicou o odpade z elektrických a elektronických zariadeniach (WEEE) a v zhode s miestnymi zákonmi vz ahujúcimi sa na túto smernicu.

Podrobnejšie informácie o Smernici WEEE nájdete na [www.fellowesinternational.com/WEEE](http://www.fellowesinternational.com/WEEE)

---

## Hungarian

Ez a termék Elektromos és elektronikus berendezés besorolású. Ha eljönne az id ő, amikor ki kell dobni a terméket, akkor kérjük, gondoskodjon arról, hogy ezt az Európai elektromos és elektronikus berendezések hulladékáról szóló (WEEE) irányelv szerinti tege, megfelelően az irányelvhöz kapcsolódó helyi törvényeknek is.

A WEEE Irányelvvel vonatkozó további információkért kérjük, keresse fel a [www.fellowesinternational.com/WEEE](http://www.fellowesinternational.com/WEEE) internetes címet

---

## Portuguese

Este produto está classificado como Equipamento Eléctrico e Electrónico. Quando chegar a altura de eliminar este produto, certifique-se de que o faz em conformidade com a Directiva relativa a Resíduos de Equipamentos Eléctricos e Electrónicos (REEE) e em observância da legislação local relativa a esta directiva.

Para obter mais informações sobre a Directiva relativa a Resíduos de Equipamentos Eléctricos e Electrónicos (REEE), visite o endereço [www.fellowesinternational.com/WEEE](http://www.fellowesinternational.com/WEEE)

---

## Declaration of Conformity

### Fellowes Manufacturing Company

Yorkshire Way, West Moor Park  
Doncaster, South Yorkshire, DN3 3FB, England  
declares that the product  
Model FS-9C

conforms with the requirements of the Restriction of Hazardous Substances Directive (2002/95/EC), the Low Voltage Directive (73/23 EEC) and the Electromagnetic Compatibility Directive (89/336 EEC) and the following harmonized European Normes (EN Standards) and IEC Standards.

Safety: EN60950 'Information Technology Equipment'

**EMC: Standard**

EN 55014-1:2000+A1+A2  
EN 55014-2:1997+A1  
EN 61000-3-2:2000  
EN 61000-3-3:1995+A1

Itasca, Illinois, USA  
June 30, 2006

  
James Fellowes

### Help Line

Australia	+ 1-800-33-11-77
Canada	+ 1-800-665-4339
México	+ 1-800-234-1185
United States	+ 1-800-955-0959

### Fellowes

Australia	+ 61-3-8336-9700
Benelux	+ 31-(0)-76-523-2090
Canada	+ 1-905-475-6320
Deutschland	+ 49-(0)-5131-49770
France	+ 33-(0)-1-30-06-86-80
Italia	+ 39-071-730041
Japan	+ 81-(0)-3-5496-2401
Korea	+ 82-2-3462-2884
Malaysia	+ 60-(0)-35122-1231
Polska	+ 48-(0)-22-771-47-40
España	+ 34-91-748-05-01
Singapore	+ 65-6221-3811
United Kingdom	+ 44-(0)-1302-836836
United States	+ 1-630-893-1600

# www.fellowes.com

**Fellowes**

1789 Norwood Avenue, Itasca, Illinois 60143-1095 • USA • 630-893-1600

<http://www.fellowes.com>

Australia  
Benelux

Canada  
China

Deutschland  
España

France  
Italia

Japan  
Korea

Polska  
Singapore

United Kingdom  
United States