

OPTIMUM QUALITY MAXIMUM RELIABILITY™



OCS320

cardboard shredder



Operating Instructions

OPTIMUM QUALITY MAXIMUM RELIABILITY™



OCS320

Machine Specification

Description

The Optimax OCS320 Cardboard Shredder is a single phase machine designed for use to shred cardboard up to 12mm thick, consisting of up to 5 layers of kraft paper with a weight between 60gsm and 300gsm.



Technical Data:

Loading width – cardboard size:	unlimited
Cutting width:	320 mm
Cardboard thickness:	12 mm
Throughput rate:	12 mtr/min
Motor capacity:	1.1 kW
Mains voltage:	230-240V 50-60Hz
Noise Emission:	free running 64dB(A)
	under load 78dB(A)
Dimensions D x W x H:	660 x 730 x 970 mm
Weight:	143 kg

OPTIMUM QUALITY MAXIMUM RELIABILITY™



Intended Use

- > This machine is intended for use in an indoor industrial environment by one adult. The machine must not be operated in explosive, corrosive or outdoor or otherwise domestic or publicly accessible environment, by multiple persons, or by children or persons of limited mental capacity.

Limitations

- > This machine is designed for a duty cycle of 3 hours in every 24 with normal maintenance. Operation in excess of this is considered heavy use and is subject to increased frequency of maintenance as detailed in this manual.
- > This machine is designed for use to shred cardboard up to 12mm thick, consisting of up to 5 layers of kraft paper with a weight between 60gsm and 300gsm. Operation with cardboard outside of these parameters is subject to testing and approval of the material by our technical department, and may be subject to additional operating time or maintenance constraints.
- > This machine is not designed to shred any other materials – in particular it is not designed to shred paper or printed materials, plastic, or cardboard with staples or metal closures in. Individual staples will not cause damage, however rows of staples or any other metal objects can cause damage and will invalidate the warranty.

Safety and Compliance Information

Operator Warnings

- > Only one person at a time is to operate the machine.
- > Children must not operate this machine.
- > Before using, tie back long hair and remove any neckties, jewellery, scarves or any other loose items that may present a risk of getting caught in the machine.
- > Do not insert fingers or any tool/other object into the feed aperture.
- > In the event of emergency, stop the machine with the emergency stop button, and disconnect from the mains power supply.
- > Always disconnect the machine from the mains power supply before opening the housing for any cleaning or maintenance work.
- > Repairs on this machine must only be carried out by a trained technician.

Airborne Emissions

- > The A-weighted emission sound pressure level at workstations, where this exceeds 70 dB(A); where this level does not exceed 70 dB(A), this fact must be indicated.
- > The peak C-weighted instantaneous sound pressure value at workstations, where this exceeds 63 Pa (130 dB in relation to 20 μ Pa).
- > The A-weighted sound power level emitted by the machinery, where the A-weighted emission sound pressure level at workstations exceeds 80 dB(A).

OPTIMUM QUALITY MAXIMUM RELIABILITY™



ISO13857 Information

> This machine complies with BS EN ISO 13857:2008 safety distances for persons over 14 years of age, as shown in the following diagram.

Part of body	Illustration	Opening	Safety distance, s_r		
			Slot	Square	Round
Fingertip		$e \leq 4$	≥ 2	≥ 2	≥ 2
		$4 < e \leq 6$	≥ 10	≥ 5	≥ 5
Finger up to knuckle joint		$6 < e \leq 8$	≥ 20	≥ 15	≥ 5
		$8 < e \leq 10$	≥ 80	≥ 25	≥ 20
Hand		$10 < e \leq 12$	≥ 100	≥ 80	≥ 80
		$12 < e \leq 20$	≥ 120	≥ 120	≥ 120
		$20 < e \leq 30$	$\geq 850^a$	≥ 120	≥ 120
		$30 < e \leq 40$	≥ 850	≥ 200	≥ 120
Arm up to junction with shoulder		$40 < e \leq 120$	≥ 850	≥ 850	≥ 850

The bold lines within the table delineate that part of the body restricted by the opening size.

^a If the length of the slot opening is ≤ 65 mm, the thumb will act as a stop and the safety distance can be reduced to 200 mm.

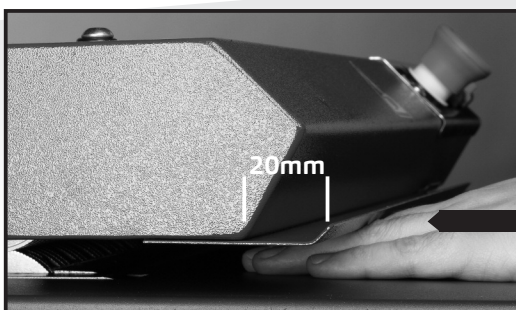

Additional 20mm safety guard fitted to all Optimax Shredders



OPTIMUM QUALITY MAXIMUM RELIABILITY™



CE and UKCA Declarations

EC Declaration of Conformity of the Machinery

This declaration relates exclusively to the machinery in the state in which it was placed on the market, and excludes components which are added and/or operations carried out subsequently by the final user.

Suppliers name:	Southgate Global Limited,
Suppliers address:	Sterling House, Hamlin Way, Hardwick Narrows Industrial Estate, King's Lynn, Norfolk, PE30 4NG, United Kingdom
Name and address of the person authorised to compile the technical file:	Lucy Merifield Address as above
Model No.:	Optimax® OCS320
Description of equipment:	Electronic Single Phase Cardboard Shredder
Harmonised legislation applied:	The machinery fulfils all the relevant provisions of Directive 2006/42/EC and also fulfils all the relevant provisions of Directive 2014/30/EU
The following harmonised standards were applied to the design of the machine:	EN ISO 13857: 2019 ISO 14121-1: 2007 EN 1009 + A2: 2008 EN 614-2 + A1 2008 EN 60204-1: 2006 EN 1005-2 +A1 2008 EN 55011 dated 1997 EN 1005-3 +A1 2008 EN 61000-1: 2006 EN ISO 13849-1: 2015 EN ISO 12100: 2010 EN ISO 14120: 2015

This machinery fulfils all the relevant provisions of the Directive and where appropriate and also conforms with other Directives and/or relevant provisions with which the machinery complies.

I the undersigned hereby declare that the equipment specified above conforms to the above Directives and Standards.

Signed for and on behalf of:

**Southgate Global Limited
20-07-22 King's Lynn, Norfolk, UK**



Full name:
Position:

**Lucy Merifield
Quality & Compliance Manager**

OPTIMUM QUALITY MAXIMUM RELIABILITY™



Installation

Location

- > Place the machine in a safe location, away from risk of damage from industrial trucks or vehicles. Ensure adequate space is provided at the front and rear of the machine for the operator and the outfeed of material – it is recommended to use a container to receive the shredded card from the rear output of the machine.

Connection to electrical supply

- > When the machine is in its location, connect the machine to the power supply. The OCS320 is fitted with a 2 metre power lead and a BS1363 13 amp fused plug.

Dust Extraction

- > The OCS320 may optionally be fitted with a dust extraction system, to reduce the amount of airborne dust and particles the machine produces. This connects to the dust extraction port on the machine, shown in the diagram.

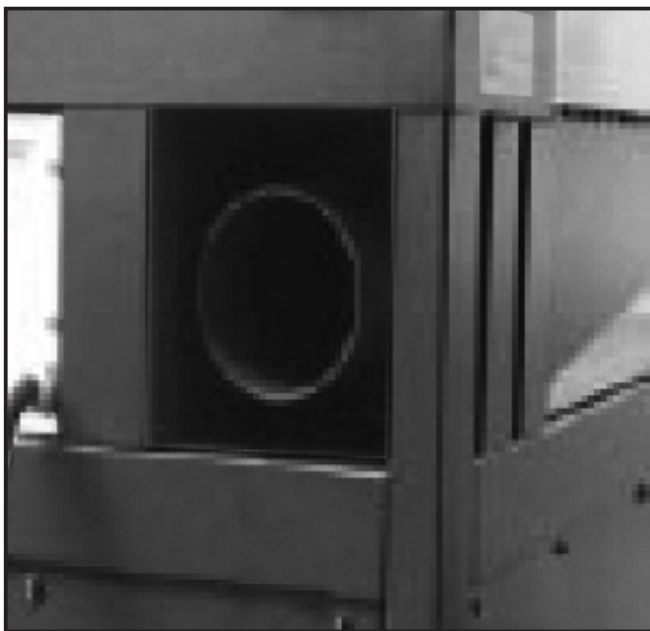

Built-in dust extraction device



Optimax® dust extractors are available from your authorised Optimax® distributor.

OPTIMUM QUALITY MAXIMUM RELIABILITY™



Operation

Machine Controls

1. Feed slot
2. Exit flap
3. Emergency stop button
4. Power 'on' indicator
5. Operation on/off rocker switch
6. Main power switch

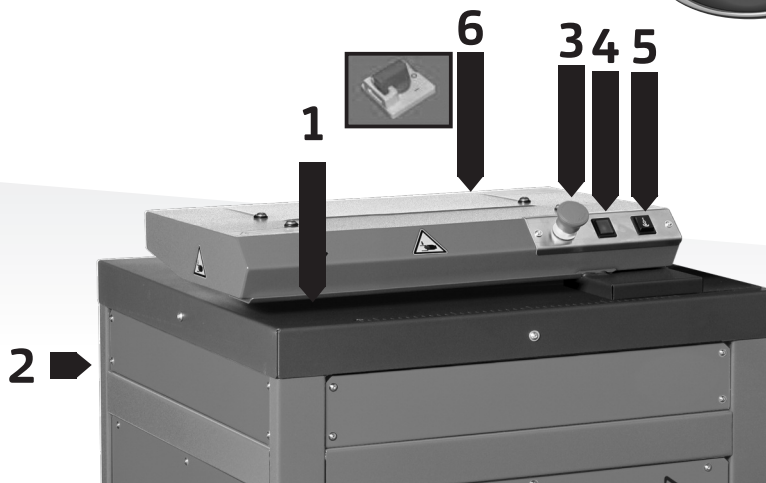

Before Use

- > Prior to use, ensure all safety devices are fitted and undamaged, and that all panels are fitted and secure.

Usage Instructions

- > Connect to the mains power supply and turn on the main power switch (6) – the power indicator (4) will light up.
- > Move the rocker (5) switch to the forward position to begin operation.
- > Feed cardboard into the feed slot (1) and the machine will feed it through.
- > To produce protective cardboard matting, release the 2 springs from the exit flap (2).
- > To produce void fill material, hook the 2 springs into the slots on the edges of the exit flap (2). Note that in this mode typically several sheets will have to be fed into the machine before it starts to produce material.
- > If the machine jams on the cardboard or is otherwise overloaded it will slow down and stop. If this happens, switch the rocker switch (5) to the 'O' position and then press and hold in the 'R' position to reverse the machine and release the jam.
- > To switch off the machine under normal conditions, move the rocker switch (5) to the central 'O' position.
- > To stop the machine in an emergency, press the emergency stop button (3).
- > To restart the machine after activating the emergency stop, twist the emergency stop button (3) to release it, then press and hold the rocker switch (5) to the 'R' position for approximately a second. The power light (4) will light up and the machine can then be used as normal.
- > **DO NOT USE THE EMERGENCY STOP TO STOP THE MACHINE IN NON-EMERGENCY SITUATIONS, OR AS A POWER ISOLATOR.**

After Use

- > After use, ensure the machine is turned off and the power is isolated to prevent any risk of accidental operation.

Transportation of Machine

- > When transporting the machine precautions must be taken as it has a high and offset centre of gravity. It is safest to lay the machine down on one side if possible, if not extra attention must be given to securing the machine from unintended movement.

OPTIMUM QUALITY MAXIMUM RELIABILITY™



Maintenance and Service

Weekly (or Daily for heavy use applications)

- > Lubricate the cutters with a chain or light mineral oil spray – direct this in through the feed slot, working along the length of the head, allowing enough coverage to ensure the cutters are fully coated.
- > **DO NOT USE WD-40 OR SIMILAR PENETRATING/RELEASE AGENTS – THESE ARE NOT LUBRICATING OIL AND WILL DISSOLVE THE GREASE IN THE HEAD. USE OF THIS TYPE OF PRODUCT WILL INVALIDATE THE WARRANTY.**

Monthly (or Weekly for heavy use applications)

- > Clean and grease the head and drive train.

Grease

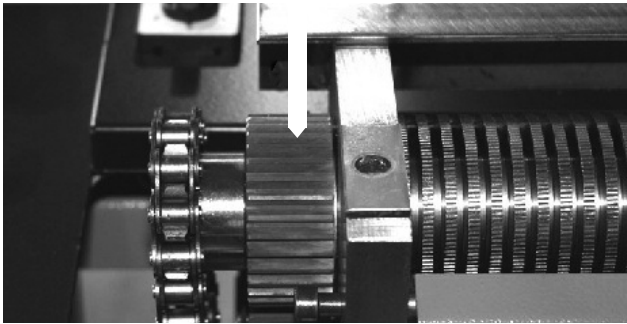

Spray Chain Oil

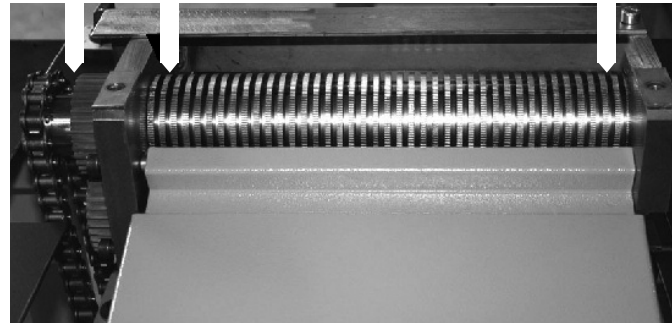

1. Ensure the machine is disconnected from the power supply.
2. Remove the 4 screws from the top cover and lift up the cover.
3. Remove the 4 screws securing the left hand over panel and remove the panel.
4. Remove all dust and cardboard residue from the head and motor with a vacuum cleaner.
5. Apply lithium or calcium grease to the chain and gears with a brush or grease gun (picture).
6. Spray chain or light mineral oil onto the bearing plates and cutters (picture).
7. Refit the side and top covers and secure with the screws.
8. Test the machine for correct operation.

If any cover/guard fixings are lost or misplaced they must be replaced with fixings of the same or higher specification and performance before the machine is used.

Quarterly (or monthly for heavy use applications)

- > Check all safety devices for correct function and any signs of damage.
- > Remove side panels and thoroughly clean out all cardboard dust and residue.
- > Visually inspect chain and motor/gearbox housing for any signs of damage, fractures or oil leaks.

Annually

- > Have the machine serviced by an authorised person.

OPTIMUM QUALITY MAXIMUM RELIABILITY™



Parts Lists

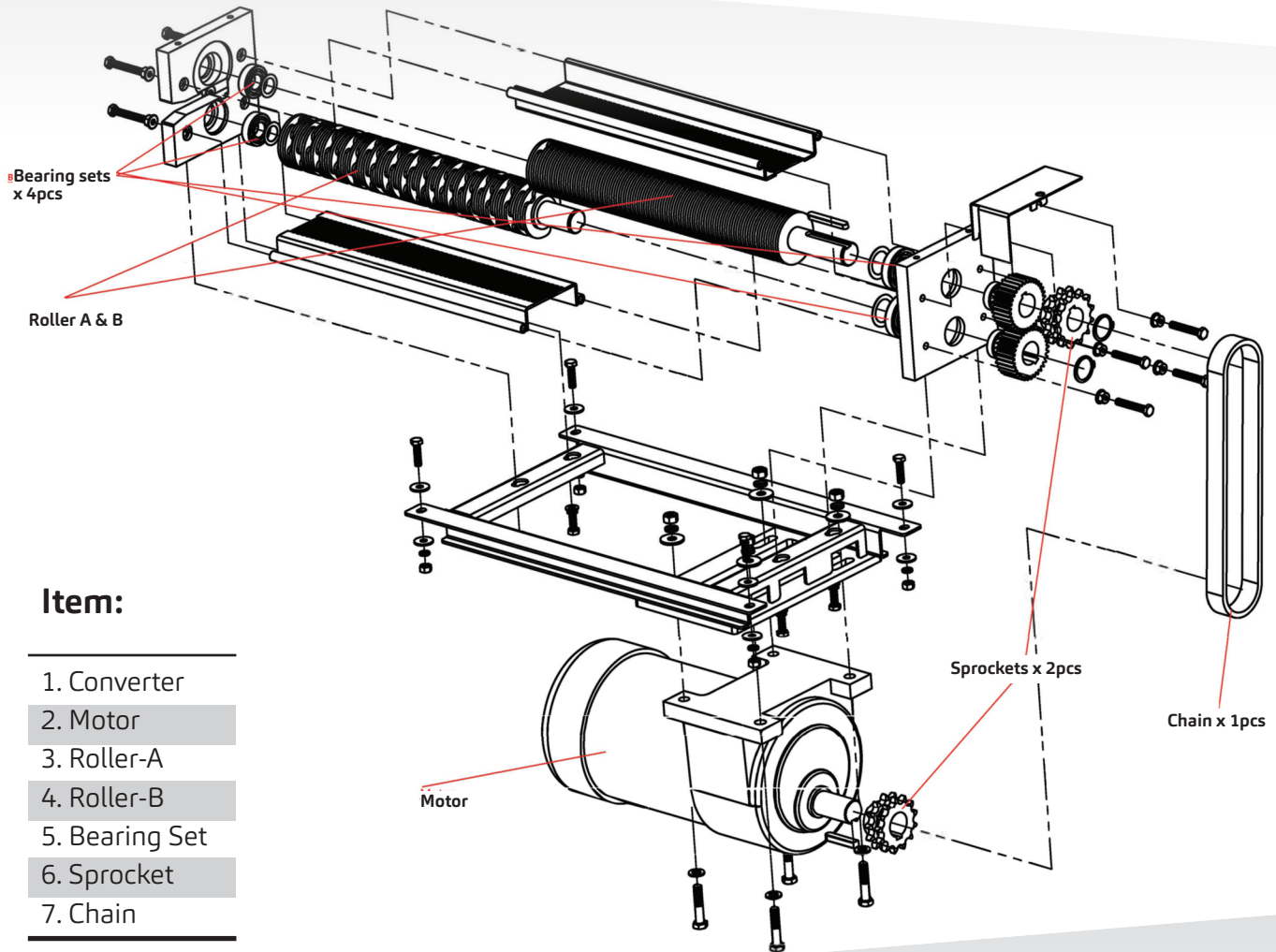

Item:

1. Converter
2. Motor
3. Roller-A
4. Roller-B
5. Bearing Set
6. Sprocket
7. Chain

Technical Support details

- > +44 1553 612161
- > service@southgateglobal.com

OPTIMUM QUALITY MAXIMUM RELIABILITY™



The Optimax® brand is a global standard that encapsulates the very best packaging equipment, innovation, engineering and consumables available to the packaging professional.

Optimax® offers a comprehensive technical advice service and training programme to ensure you maximise the full operating potential of your Optimax® packaging equipment.



Our highly trained technical team and European network of authorised distributors can offer training either on-site or at an Optimax® training centre.



OPTIMUM QUALITY MAXIMUM RELIABILITY™



Optimax® aftersales service offers complete peace of mind via our technical service centre, highly trained technicians and comprehensive parts and spares operation.

To ensure your Optimax® packaging equipment is maintained to the highest operating standards, the Optimax® technical service centre provides full technical support and service for our distinctive and evolving product range.

In addition to our large stock holding of spare parts, we have many years of experience in packaging equipment service and repair, which help to minimise the downtime in your packaging operation.



Please contact your authorised Optimax® distributor for more information on the Optimax® range of training and aftersales maintenance and service packages.

OPTIMUM QUALITY MAXIMUM RELIABILITY™



OCS320

cardboard shredder

Operating Instructions



©Packaging Brands Ltd
OCS320 Operating Instructions 12.2022
Re-order code: LIT-MAN003

No part of this publication may be reproduced or transmitted in any form or by any means without the express written authorisation of Packaging Brands Ltd. Optimax® is a registered trademark of Packaging Brands Ltd.

For more information on shredders and other packaging equipment in the Optimax® range, or to find your preferred or appointed distributor please call 0333 005 9603 or email optimax@packagingbrands.eu.com